

3M™ MicroTouch™ Controller EX Serial Reference Guide

Formerly
17xxSC now EX122
77xxSC now EX112

Read and understand all safety information
contained in this document before using this product.



The information in this document is subject to change without notice. No part of this document may be reproduced or transmitted in any form or by any means, electronic or mechanical, for any purpose, without the express written permission of 3M Touch Systems, Inc. 3M may have patents or pending patent applications, trademarks, copyrights, or other intellectual property rights covering subject matter in this document. The furnishing of this document does not give you license to these patents, trademarks, copyrights, or other intellectual property except as expressly provided in any written license agreement from 3M Touch Systems, Inc.

The information provided in this document is intended as a guide only. For the latest detailed engineering specifications, please contact your 3M Touch Systems, Inc. Application Engineer. 3M Touch Systems, Inc. is committed to continually improving product designs. As a result, product specifications may be subject to change without notification.

"RoHS compliant 2005/95/EC" means that the product or part does not contain any of the following substances in excess of the following maximum concentration values in any homogeneous material, unless the substance is in an application that is exempt under RoHS: (a) 0.1% (by weight) for lead, mercury, hexavalent chromium, polybrominated biphenyls or polybrominated diphenyl ethers; or (b) 0.01% (by weight) for cadmium. This information represents 3M's knowledge and belief, which may be based in whole or in part on information provided by third party suppliers to 3M.

NOTICE: Given the variety of factors that can affect the use and performance of a 3M Touch Systems, Inc. product (the "Product"), including that solid state equipment has operation characteristics different from electromechanical equipment, some of which factors are uniquely within User's knowledge and control, it is essential that User evaluate the 3M Touch Systems, Inc. Product and software to determine whether it is suitable for User's particular purpose and suitable for User's method of application. 3M Touch Systems, Inc. statements, engineering/technical information, and recommendations are provided for User's convenience, but their accuracy or completeness is not warranted. 3M Touch Systems, Inc. products and software are not specifically designed for use in medical devices as defined by United States federal law. 3M Touch Systems, Inc. products and software should not be used in such applications without 3M Touch Systems, Inc. express written consent. User should contact its sales representative if User's opportunity involves a medical device application.

IMPORTANT NOTICE TO PURCHASER: Specifications are subject to change without notice. These 3M Touch Systems, Inc. Products and software are warranted to meet their published specifications from the date of shipment and for the period stated in the specification. **3M Touch Systems, Inc. makes no additional warranties, express or implied, including but not limited to any implied warranties of merchantability or fitness for a particular purpose.** User is responsible for determining whether the 3M Touch Systems, Inc. Products and software are fit for User's particular purpose and suitable for its method of production, including intellectual property liability for User's application. If the Product, software or software media is proven not to have met 3M Touch Systems, Inc. warranty, then 3M Touch Systems, Inc. sole obligation and User's and Purchaser's **exclusive remedy**, will be, at 3M Touch Systems, Inc. option, to repair or replace that Product quantity or software media or to refund its purchase price. 3M Touch Systems, Inc. has no obligation under 3M Touch Systems, Inc. warranty for any Product, software or software media that has been modified or damaged through misuse, accident, neglect, or subsequent manufacturing operations or assemblies by anyone other than 3M Touch Systems, Inc. **3M Touch Systems, Inc. shall not be liable in any action against it in any way related to the Products or software for any loss or damages, whether non-specified direct, indirect, special, incidental or consequential (including downtime, loss of profits or goodwill) regardless of the legal theory asserted.**

© 3M 2001-2009 All rights reserved.

Document Title: *3M™ MicroTouch™ Controller EX Serial Reference Guide*
Document Number: 29087, Version 02

3M, the 3M logo, MicroTouch, and the MicroTouch logo are either registered trademarks or trademarks of 3M in the United States and/or other countries.

Windows and/or other Microsoft products referenced herein are either registered trademarks or trademarks of Microsoft Corporation in the U.S. and/or other countries.

All other trademarks are the property of their respective owners.

Contents

Chapter 1	Introduction	
	What You Need to Know	5
	Important Safety Information	5
	Sensor Care and Cleaning	6
	3M Touch Systems Support Services	7
	Contact 3M Touch Systems	7
Chapter 2	Integrating 3M™ MicroTouch™ EX Serial Controllers	
	Overview of the EX Serial Controllers	9
	Handling and ESD Protection	10
	EX Serial Controller Communication Connections	10
	EX122 Sensor Cable Connections	11
	EX112 Sensor Cable Connections	11
	Mounting the Controller	11
	Supplying Power to the Controller	12
	Mounting the Sensor	13
	Turning On Your System	13
	Status Light (LED) Diagnostics	13
	Installing 3M™ MicroTouch™ Software	15
Chapter 3	3M™ MicroTouch™ EX Serial Controller Communications	
	Overview of Firmware Commands	17
	Controller Default Settings	18
	Communicating with the Controller	18
	Firmware Commands	20
	Calibrate Extended	21
	Calibrate Raw	23
	Diagnostic Command	25
	Format Raw	25
	Format Tablet	27
	Mode Stream	28

	Name Command	28
	Null Command	28
	Output Identity	29
	Parameter Set.....	29
	Reset	30
	Restore Defaults	30
	Unit Type Verify	31
Appendix A	EX122 Controller Specifications	
	Technical Specifications.....	34
	Physical Dimensions	34
Appendix B	EX112 Controller Specifications	
	Technical Specifications.....	38
	Physical Dimensions	38

CHAPTER 1

Introduction

3M Touch Systems offers several advanced controllers designed for reliability and easy installation. Each controller provides superior performance and delivers excellent stability, sensitivity, accuracy, and fast response.

This reference guide, designed for developers of touch systems, provides installation and configuration information for the 3M™ MicroTouch™ EX serial capacitive touch controller. This document includes information on integrating the EX serial controller into your design, communicating with the controller, installing the MT 7 software user interface, and troubleshooting setup problems. It also includes a complete description of the firmware commands and controller specifications.

3M Touch Systems is committed to being a premier supplier in touch systems throughout the world. As a 3M Touch Systems customer, you are aware that we have strong internal programs that meet or exceed environmental regulations of our customers and the regions in which we conduct business.

What You Need to Know

This document assumes you are familiar with firmware commands and how to use them. Executing some commands may alter the performance of your touch product. You should be aware of the results of using these commands before executing them.

Important Safety Information

Read, understand and follow all safety information before using this product. Follow all instructions marked on the product and described in this document. Pay close attention to the following installation warnings and safety precautions.

Intended Use
The EX serial controller was designed to enable surface capacitive touch in conjunction with other 3M™ MicroTouch™ sensor products and was tested to replace an existing serial controller. This controller is intended for internal mounting only and is not suitable for use in hazardous locations.

Explanation of Signal Word Consequences

⚠ WARNING: Indicates a potentially hazardous situation, which, if not avoided, could result in death or serious injury and/or property damage.

⚠ CAUTION: Indicates a potentially hazardous situation, which, if not avoided, may result in minor or moderate injury and/or property damage.

CAUTION: Indicates a potentially hazardous situation, which, if not avoided, may result in property damage.

⚠ WARNING

To reduce the risk of fire and/or explosion which could result in serious injury or death:

Do not install or use this product in a hazardous location.

To reduce the risk of fire and/or explosion which could result in serious injury or property damage:

Do not use this product in any outdoor environment unless NEMA standards (or similar standards such as IP rating) are followed.

To avoid the risk of electric shock which could result in serious injury or death:

- Do not use a damaged power supply.
- Do not use a power cord that is frayed or otherwise damaged.

⚠ CAUTION

To reduce the risks associated with improper disposal, which if not avoided may result in minor or moderate injury from ground water contamination:

Dispose of components in accordance with federal, state and local regulations.

To reduce the risk of possible environmental contamination which may result in minor or moderate injury:

Dispose of the display in accordance with federal, state and local regulations.

To avoid the potentially hazardous situations associated with the use of isopropyl alcohol which may result in minor or moderate injury or property damage:

Follow all instructions and recommendations in the manufacturer's Material Safety Data Sheet and product label.

Sensor Care and Cleaning

The sensor requires very little maintenance. 3M Touch Systems recommends that you periodically clean the glass surface.

⚠ CAUTION

To reduce the risk of the potentially hazardous situations associated with the use of isopropyl alcohol which may result in minor or moderate injury or property damage:

Follow all instructions and recommendations in the alcohol manufacturer's Material Safety Data Sheet and product label.

Typically, an isopropyl alcohol and water solution ratio of 50:50 is the best cleaning agent for your touch screen. You can also use straight isopropyl alcohol. Be sure to follow solvent manufacturer's precautions and directions for use when using any solvents.

- It is important to avoid using any caustic chemicals on the sensor.
- Always dampen the cloth and then clean the screen. Be sure to spray the cleaning liquid onto the cloth, not the screen, so that drips do not seep inside the display or stain the bezel.
- Apply the cleaner with a soft, lint-free cloth. Avoid using gritty cloths.
- Always handle the sensor with care. Do not pull on or stress flex tail.

3M Touch Systems Support Services

3M Touch Systems provides extensive support services through our website and technical support organization. Visit the 3M Touch Systems website at <http://www.3M.com/touch>, where you can download touch software and drivers, obtain regularly updated technical documentation on 3M Touch Systems products, and learn more about our company.

Whenever you contact Technical Support, please provide the following information:

- Touch display size, part number and serial number
- Current driver version
- Operating system used
- Information on additional peripherals

Technical Support is available Monday through Friday 8:30 a.m. to 5:30 p.m. with limited call back service after 5:30 p.m. until 8:00 p.m. US Eastern Standard Time – 9 a.m. to 5 p.m. throughout Europe.

You can contact 3M Touch Systems Technical Support (US only -- Eastern Standard Time) by calling the hot line, sending email or a fax.

- Technical Support Hot Line: 978-659-9200
- Technical Support Fax: 978-659-9400
- Toll Free: 1-866-407-6666 (Option 3)
- Email: US-TS-techsupport@mmm.com

Contact 3M Touch Systems

Contact information for all offices can be found on our website at:

<http://www.3M.com/touch/>

CHAPTER 2

Integrating 3M™ MicroTouch™ EX Serial Controllers

The 3M™ MicroTouch™ EX serial controller provides a drop-in replacement for an existing controller with wide dynamic range, increased noise immunity, wide operating temperature stability, reprogrammability using software utilities and improved capability in ungrounded environments.

The EX122 and EX112 series capacitive controller firmware is optimized for surface capacitive sensors integrated in the latest flat panel displays.

This chapter covers the following EX serial controller specifications:

- Cable connections
- Mounting requirements
- Power requirements and options
- Status LED codes

Overview of the EX Serial Controllers

Note: For complete specifications for each of these EX serial controllers, refer to the appendices at the end of this manual.

The EX serial controllers and sensors are supplied separately. A 25-point linearization procedure has been performed to determine the physical properties of the sensor, and the data is stored in a 2D bar code label attached to the flex tail.

- The EX122 is available in N81 or N72, Format Tablet, cased or uncased for either external or internal mounting.
- The EX112 is available in N81 Format Tablet uncased without cable for mounting within a custom chassis.

To integrate and test the EX serial controller, you need the following items:

- A 3M™ MicroTouch™ surface capacitive sensor. These sensors are available in a variety of sizes.

- A method of establishing the serial data communication between the controller and your system. The standard 3M™ MicroTouch™ RS-232 serial cable (P/N 7310101) is recommended.
- A method of supplying power to the controller -- either internal or external.
- A touch driver with a calibration routine. You can use 3M™ MicroTouch™ MT 7 software which includes the necessary touch driver and utilities software.

Handling and ESD Protection

When mounting the sensor and controller, use normal precautions for handling electrostatic sensitive devices. The EX serial controllers have internal protection to ± 27 kV for ESD discharges to the sensor (not to the controller directly) that may occur during normal operation of the sensor. Refer to the appendices for further specifications.

EX Serial Controller Communication Connections

You will need a method of establishing the serial data communication between the controller and your system. You can build your own or purchase the standard 3M™ MicroTouch™ RS-232 serial cable (P/N 7310101). Table 1 describes the pins for this cable, which connects to a serial communication (COM) port on the PC.

Table 1 COM Connections for EX Serial Controllers

9-pin D	7-pin Molex	Wire Color	Description
1	No connection	———	Data Carrier Detect (DCD). Connected to DTR and DSR.
2	2	Brown	Transmit Data (TXD). Pin 2 is the controller's output to the host.
3	3	Red	Receive Data (RXD). Pin 3 is the controller's receive from the host.
4	No connection	———	Data Terminal Ready (DTR). Connected to DSR and DCD.
5	5	Blue	Power supply ground.
6	No connection	———	Data Set Ready (DSR). Connected to DTR and DCD.
7	1	Black	Request To Send (RTS). Connected to CTS.
8	4	Green	Clear To Send (CTS). Connected to RTS.
9	Not used		
Sleeve	6	White	DC power jack (+5 VDC).
Pin	7	Shield	Cable shield connected to ground DC power jack (ground)
Shell	7	———	Chassis (earth) ground.

EX122 Sensor Cable Connections

The sensor cable has a 12-pin (2 x 6) dual row female connector that plugs into the controller. Table 2 describes the pins on this connector. The sensor connector always exits towards the serial cable.

Table 2 Sensor Cable Connector for EX122 Controllers

Pin	Wire Color	Description
1	————	NOVRAM interface
2	————	NOVRAM interface
3	————	NOVRAM interface
4	————	+5 VDC
5	Gray	Power supply ground
6	Green	Chassis (earth) ground
7	Orange	+12V input
8	Brown Cable shield/drain wire	Connects to the flex tail shield, which must not be grounded because the EX122 drives the flex tail shield with an AC waveform.
9	White	Upper right (UR) corner
10	Red	Lower right (LR) corner
11	Black	Upper left (UL) corner
12	Blue	Lower left (LL) corner

EX112 Sensor Cable Connections

The sensor cable has a 5-pin single row locking female connector that plugs into the controller. Table 3 describes the pins on this connector.

Table 3 Sensor Cable Connector for EX112 Controllers

Pin	Wire Color	Description
1		Upper left (UL) corner
2		Upper right (UR) corner
3	Cable shield/drain wire	Connects to the flex tail shield, which must <i>not</i> be grounded because the EX112 drives the flex tail shield with an AC waveform.
4		Lower right (LR) corner
5		Lower left (LL) corner

Mounting the Controller

The cased controller is mounted externally. The uncased controller is mounted internally. Choose a convenient spot away from high-voltage, high power cables and electronics. Use 4-40 plastic screws to mount the cased controller to eliminate possible ESD input path. Metal or plastic screws can be used on the 2x3 board if the green ground wire is used. Metal screws are required on the 1x2 board if a separate ground wire is not used.

The controller should be mounted in line with the sensor flex tail exit point to minimize flexing. Refer to Figure 1 for more details on controller mounting.

Supplying Power to the Controller

You must supply the EX serial controller with power. You can use internal power (that is, tap power from inside the display or PC) or external power.

However you supply power, the source must deliver 85 mA typical (110 mA maximum), with a maximum ripple and noise of 50mV peak-to-peak.



CAUTION

To avoid possible damage to the controller, you must provide a path for electrostatic discharge. The controller-mounting hole near the sensor connector should be used to connect to chassis safety ground and must be attached by the shortest possible route to a good earth return (chassis) in all applications.

You can supply power to the controller using any of the following methods. The voltage input can vary from +5VDC to +12VDC. Exact specifications can be found in the appendices.

- (EX112 only) Internal power +5V to +12 V DC through the 2-pin power input connector pin 2 (+5V to 12 V) and pin 1 (RTN). A square pin indicator on the bottom of the board marks pin 1.
- Internal power (+5V to +12V DC) through a custom serial cable configuration.
- External power (+5 V DC) from a wall-mount power supply.

Note: To avoid possible damage to one or both of the power supplies, do not supply both internal power and external power to the controller. Power from two sources could cause damage.

Using an Internal Power Supply (+5V to +12V) to JP3

Provide power directly to the controller using JP3 (Molex 22-05-3021). Use a mating 2-pin connector and connect Pin 2 to power (between +5V and +12V) and Pin 1 to the return. (Mating connector is the Molex housing 22-01-3027 with 08-50-0114 contacts).

Using a Custom Serial Cable Design

When creating a custom serial cable connection, you can provide power to the controller through the mating Molex connector: (refer to Table 12 for more information on actual cable connections).

1. Obtain a 7-pin Molex connector 51004-0700.
2. Attach power and ground to the connector, (Pin 6: +5V to +12V, Pin 7: Ground).

Using an External Wall-Mount Power Supply

If you are using a standard 3M™ MicroTouch™ RS-232 serial cable (P/N 7310101), consult your applications engineer for power supply specifications.

Mounting the Sensor

There are several methods for mounting the sensor depending on your application. If you need instructions or recommendations from 3M Touch Systems on how to incorporate a sensor into your design, refer to the *3M™ MicroTouch™ System 3250EX Integration Guide* (P/N 19-278). All 3M Touch Systems documentation is available from the corporate website at www.3Mtouch.com.

Turning On Your System

Before you turn on your touch system, ensure that all cables are connected properly and that the controller is properly mounted. Be sure to tighten all cable connector screws.

To start up your system:

1. Turn on your display and computer.
2. Adjust the contrast and brightness to suit your personal preference and working environment.
3. Adjust the horizontal and vertical position controls on the display to center the image on the screen.

Status Light (LED) Diagnostics

3M™ MicroTouch™ controllers are highly reliable units; however, there may be occasions when the controller does not perform exactly as you expected. The EX serial controller provides diagnostic feedback with a light emitting diode (LED) on the component side of the board that indicates the status of the touch system.

If the LED is on, and remains dimly lit, the controller has power and is operating properly. If the LED is off, the controller is not receiving power.

When you power-up the unit, the LED is bright until the controller start-up sequence is completed. Following start-up, the LED becomes dim and remains dim as long as you do not touch the sensor. When you touch the sensor, the LED becomes bright as long as a touch is detected.

A flashing (or blinking) LED during power-up indicates the controller's power-on self-test failed. Refer to Table 4 for a description of each error code.

Table 4 LED Diagnostic Codes for EX Serial Controllers

Self Test Condition	LED Flashes	Self Test Bit	Description	What to do...
RAM Data Error ²	1	0	Data side checksum error	Reload program code.
RAM Code Error ²	2	1	Firmware EEPROM checksum verification error	Reload program code.
STRAY Error ¹	3	2	Unable to initialize stray cancellation	Replace controller. If error reoccurs, might be a sensor problem.
NOV Error ³	4	3	Parameters invalid (using defaults)	Restore defaults. If fault persists, replace controller. If error reoccurs, might be a sensor or cable problem.
HDW Error ¹	5	4	Controller hardware failure (phase/gain initialization)	Cycle power. If fault persists, replace controller.
Reserved	6	5	Reserved	
CABLE Error	7	6	Cable NOV RAM linearization data invalid	At startup, the cable NOV RAM error will flash the LED until the controller receives a status command from host.
NOV2 Error	8	7	Controller NOV RAM linearization data invalid	Replace sensor or perform a 25-point linearization. Contact Technical Support.
Reserved	9	8	Reserved	
EEPROM Error ²	10	9	EEPROM is not working	Reload program code.
NOV5 Error	11	10	Controller ID is not valid	Restore defaults. If fault persists, replace controller.
NOV6 Error	12	11	Interface configuration values are not valid	Restore defaults. If fault persists, replace controller.
NOV7 Error	13	12	Touch configuration values are not valid	Restore defaults. If fault persists, replace controller.
Reserved	14	13	Reserved	
Resistance Error	15	14	Sensor resistance is out of supported range	Cycle power. If fault persists, replace sensor.
Backplane Error	16	15	Low resistance path from backplane to sensor	Cycle power. If fault persists, replace sensor.
Corner Error	17	16	Corner drive offset level is too high	Cycle power. If fault persists, replace controller.
Fixed Cal Error	18	17	Fixed 2-point cal error high	Cycle power. If fault persists, replace controller.

Note 1: this is a fatal error.

Note 2: this error is detected by the ROM code

Note 3: indicates that the EEPROM is not formatted when given by the ROM code

Installing 3M™ MicroTouch™ Software

3M™ MicroTouch™ Software includes the driver that enables your sensor to work with your computer. 3M Touch Systems has touch drivers for many operating systems, including Windows Vista, XP, XP embedded, 2000, 9X, Windows Me, Windows CE, and Windows NT 4.0 (refer to the website for a complete listing). You must be sure to install the correct software for your operating system.

3M™ MicroTouch™ Software includes a control panel for setting your sensor preferences and a diagnostic utility. If you are experiencing problems with the sensor, you can use the diagnostic utilities provided to locate the controller and test the sensor.

For more information on connecting your cables and installing and using the sensor control panel and utilities, refer to the 3M™ MicroTouch™ Software User Guides available on the corporate website at www.3Mtouch.com.

CHAPTER 3

3M™ MicroTouch™ EX Serial Controller Communications

This chapter discusses the fundamentals of communicating with the 3M™ MicroTouch™ EX serial controller. The firmware commands, which are usually issued by a driver or utility program on the host system, control the operation of the touch controller, however developers can enter these commands directly. This chapter:

- Describes the controller default settings.
- Lists the recommended firmware commands for current development.
- Describes how to use each of these commands.
- References additional commands developers may need to use.

The description of each command includes the command syntax, the default value, how the command works, and the expected response from the controller.

Overview of Firmware Commands

Developers may use these commands when writing touch applications, developing custom drivers or touch configurations, or testing their touch systems. Developers can issue commands to initialize the controller, select operating modes, and execute diagnostic functions.

Most sensor users do *not* have to use firmware commands to use their touch systems. For example, users can use MT 7 software to calibrate the sensor or to determine the controller type and firmware version.

Note: This document assumes you are familiar with standards and modes of communication with serial devices, as well as firmware commands and how to use them. Executing some commands may alter the performance of your sensor and render it inoperable. You should be aware of the results before executing any firmware commands.

To optimize the performance of the 3M™ MicroTouch™ EX touch controller and simplify the development of custom drivers, 3M Touch Systems recommends you use the commands listed in this chapter for current development. Using these commands ensures compatibility with all 3M™ MicroTouch™ controllers.

Controller Default Settings

Communication Parameters

The default operation of the EX serial controllers is N81 (no parity, 8 data bits, and 1 stop bits) at 9600 baud. Some EX122 controllers can be programmed to work with even/odd parity, 7 data bits, and 1 or 2 stop bits.

Data Format

Data format refers to the type of packet the controller uses to send the X/Y touch coordinates to the host system. Format Tablet is the default format for the 3M™ MicroTouch™ EX serial controller. In Format Tablet, the controller sends 5 bytes per point and provides the most rapid response time to a touch.

- Format Tablet is supported by all current 3M™ MicroTouch™ touch controllers.
- It is the standard for current 3M Touch Systems product development and is the format used by all touch drivers written by 3M Touch Systems.

Refer to the Format Tablet command in the firmware reference section. Note that 3M MicroTouch Software automatically sets communications parameters to N81.

Operating Mode

The *operating mode* specifies the conditions under which the controller sends the X/Y touch coordinates (input data packet) to the host system.

Mode Stream is the default operating mode for the EX serial controller. In Mode Stream, the controller sends a continuous stream of data packets when the sensor is touched. The controller sends the data as long as a touch continues on the sensor.

Because Mode Stream sends touch data continually, it is the most versatile mode, and it provides the best response time and overall feel.

3M Touch Systems recommends that the touch driver generate an interrupt as each packet in the data stream arrives. Because touchdown and liftoff events are specially coded, your software can generate mouse events that correspond to what the user is doing. This enables instant feedback and prevents data loss.

Communicating with the Controller

This section provides information on sending firmware commands to the controller and interpreting the responses that the controller returns.

The commands listed in the following table are those that 3M Touch Systems currently uses for development. 3M Touch Systems recommends that you use only these commands for 3M™ MicroTouch™ EX serial controller development.

Commands to the controller are sent on the signal **Receive Data** (RXD) line as a serial data stream. For each command it receives, the controller sends a response to the host on the signal **Transmit Data** (TXD) line also as a serial data stream.

Sending Commands to the Controller

When you send a command to the controller, you must use the correct command format. The general format of a command is as follows:

<Header>Command<Terminator>

Note: The following descriptions of header, command, and terminator, use 3M Touch Systems terminal emulator key sequences. You may need to enter the sequence in a different format, depending on your emulator.

The *header* is the first character in the command string and is the ASCII start-of-header control character SOH. The hexadecimal code for the ASCII SOH control character is 01. To start the command sequence, use the key combination Ctrl A (^A). If you are working with an IBM PC compatible system, the Ctrl A key combination immediately returns an ASCII ☺ character.

The *command*, which always follows the header, consists of ASCII uppercase letters and numbers only (printable characters).

The *terminator* is the last character of each command string and is an ASCII carriage return CR. An ASCII CR control character is 0D hexadecimal. To enter a carriage return, ending the command sequence, use Enter or the key combination Ctrl M (^M).

This chapter lists each command as a string of ASCII control characters and printable characters consisting of a header, the command, and a terminator as follows:

<SOH>Command<CR>

Receiving Responses from the Controller

After executing a command, the controller returns a response or acknowledgment to the host system. Each controller response consists of a header, the command response, and a terminator in the following format:

<Header>Command Response<Terminator>

Note: The following descriptions of header, response, and terminator, use 3M Touch Systems terminal emulator key sequences. The format of controller responses varies depending on the terminal emulation mode you are using.

The *header* is the first character in the response string and is the ASCII start-of-header control character SOH. The hexadecimal code for the ASCII SOH control character is 01. If you are working with an IBM PC compatible system in terminal mode, the SOH control character returns a ☺ character to the sensor.

The *command response*, which always follows the header, is a range of ASCII characters depending on the type of command sent. Responses can be in many forms. For example, one standard response is **0** (ASCII character ‘zero’ or 30 hexadecimal). This response indicates a successful command completion for most commands, while it indicates a failed completion for other commands. Refer to the firmware reference section for a description of what the response indicates for *each* particular command.

Another standard response is **1** (ASCII character ‘one’ or 31 hexadecimal). In most cases, this response indicates the command failed. The controller received an invalid command that it could not execute.

Some possible reasons for a command failure include:

- The command was not formatted correctly.
- The system parameters were not set up to allow command execution.
- The controller does not support the command.

The *terminator* is the last character of each response string and is an ASCII carriage return CR. The hexadecimal code for the ASCII CR control character is 0D hexadecimal. The value returned in the response will be the ASCII control character for a carriage return, displayed on the screen as the cursor moving to the next line.

In this chapter, responses are shown as a string of ASCII characters consisting of a header, the response, and a terminator as follows:

<SOH>*Response*<CR>

Controller Initialization

To initialize the EX serial controller for new development, 3M Touch Systems recommends that the host system issue a Reset command whenever the host system is powered on and is attempting to establish communication with the controller.

Firmware Commands

Developers may use this information when writing touch applications, developing custom drivers or touch configurations, or testing their touch systems. Developers can use firmware commands to initialize the controller, select operating modes, specify data formats, and execute diagnostic functions.

Most touch systems users do *not* have to use firmware commands to use their touch systems. For example, users can use 3M™ MicroTouch™ Software to calibrate the sensor or to determine the controller type and firmware version.

Caution: This document assumes you are familiar with firmware commands and how to use them. Executing some commands may alter the performance of your touch system and render it inoperable. You should be aware of the results before executing any firmware commands.

To optimize the performance of the touch controller and simplify the development of custom drivers, 3M Touch Systems recommends you use the commands listed in Table 5 for current development. Using these commands ensures compatibility with all 3M™ MicroTouch™ controllers.

Note: When you enter commands in terminal mode, precede each command with <CTRL> A to enter the start of header.

Table 5 Firmware Commands for EX Serial Controller Development

Command	Code	Description
Calibrate Extended	CX	Initiates an interactive 2-point calibration.
Calibrate Raw	CR	Collects the raw X and Y coordinates before normal scaling, linearization, and filtering process.
Format Raw	FR	Returns the signal level (amount of touch) of each of the four sensor corners in digital format.
Format Tablet	FT	Outputs the X/Y touch coordinate data in a five-byte packet. Preferred for current development.
Mode Stream	MS	Sends a continuous stream of X/Y coordinate data when you touch the sensor.
Name	NM	Returns a controller identifier string.
Null Command	Z	Queries the controller and waits for a response.
Output Identity	OI	Identifies the controller type and the firmware version.
Parameter Set	<i>Ppds</i> [<i>b</i>]	Lets you adjust the communication parameters (parity, data bits, and stop bits) of the controller.
Reset	R	Initializes the hardware and the firmware, causes the controller to stop sending data, and recalculates the environmental conditions.
Restore Defaults	RD	Returns the controller to the factory default operating parameters. Note: the serial port is reset to N81 format tablet and 2-point calibration is lost.
Unit Type Verify	UV	Identifies the touch controller on your system.

Calibrate Extended

Syntax: <SOH>CX<CR>

Note: This command should not be used when 3M™ MicroTouch™ Software is being used. The CX command will interfere with the auto orientation algorithm. To calibrate, use the 2- or 4-point calibration in 3M™ MicroTouch™ Software.

Description: Initiates an interactive 2-point calibration.

During the calibration process, you define the active area of the sensor by mapping locations to an absolute X/Y coordinate system. You touch two *target areas* on the sensor. Touching the target areas sends the X/Y coordinates for those touch points to the controller. The controller calculates all other touch points based on these two points.

The Calibrate Extended command sets the calibration targets (points) inward from the corner of the video image. Setting the targets inward makes the calibration process easier and more accurate.

Guidelines for Calibrate Extended

Here are several guidelines for using the Calibrate Extended command:

- The controller uses the data immediately before liftoff to register a calibration touch. Therefore, you can touch the sensor, move your finger to the target, hold for a few seconds, and then lift off. Instructing users to touch this way results in a more accurate calibration.
- The controller stores the data in non-volatile memory (NOVRAM). Therefore, you do not have to calibrate the sensor each time you power on the system. You should, however, recalibrate the sensor any time the video display changes size or resolution.
- You can restart calibration at any time during this sequence by issuing a Reset command and reissuing a CX command.

Determining Target Areas

The default calibration targets (points) are located 12.5% (1/8) inward from the corners of the video image. For example, suppose the display resolution of your display is 1024 x 768. The Calibrate Extended command calculates the amount to move inward as follows:

- Amount to move inward in the X direction: $1024 \times 1/8 = 128$
- Amount to move inward in the Y direction: $768 \times 1/8 = 96$

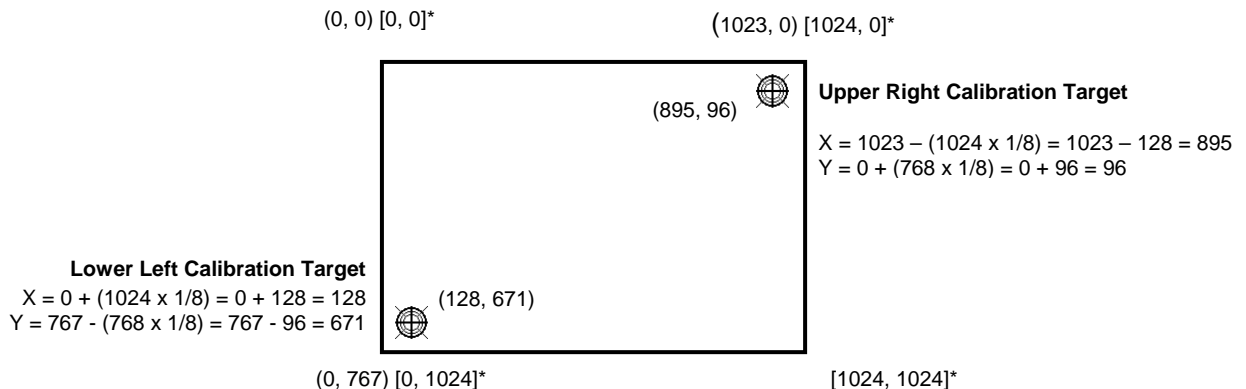

*The coordinates are in *video* terms, with the origin (0, 0) in the upper left corner of the sensor. Examples from the *controller's* perspective, however, place the origin at the lower left corner of the sensor (numbers in brackets). The controller outputs 0 to 64K on both axes independent of display screen resolution.

The Calibrate Extended command then positions the first calibration target inward from the lower left corner and the second calibration target inward from the upper right corner. The following illustration shows how the calibration targets are calculated.

Calibrate Extended Procedure

To use the CX command:

1. Enter the Calibrate Extended (CX) command. The controller sends an initial acknowledgment of <SOH>0<CR>.
2. Touch the sensor at a lower left target, which is located 12.5% (1/8) in from the corner of the video image. The controller returns an acknowledgment of <SOH>1<CR>. This is a positive response. If you receive a negative response <SOH>0<CR>, you can cancel the calibration by issuing a Reset command and then start over again.
3. Touch the sensor at an upper right target, which is located 12.5% (1/8) in from the corner of the video image. The controller returns an acknowledgment of <SOH>1<CR>. This is a positive response. If you receive a negative response, you must start over again.

Touching the two valid calibration points results in a successful calibration. If either calibration point is invalid, the calibration fails. The EX122 and EX112 controllers restore the previous calibration values. If the Calibrate Extended failed, repeat the CX process.

Response: <SOH>1<CR> Positive response.

Indicates that the controller received a valid touch coordinate (point) when the target was touched. Two valid touch points indicate a successful calibration.

<SOH>0<CR> Negative response

Indicates that the touch point is out of range of the expected target area. If you receive a negative response, you must start over again.

No Response

Indicates that you did not touch the target long enough to provide an accurate calibration point.

Calibrate Raw

Syntax: <SOH>CR<CR>

Description: Allows the collection of raw (signed) X and Y coordinates before the normal scaling, linearization, and filtering processes. The controller sends a continuous stream of data in Calibrate Raw mode.

The Calibrate Raw data is a 5-byte packet that includes 1 status byte and 4 bytes of binary X/Y coordinate data. Each X/Y coordinate includes 10 binary bits and 1 sign bit. The 10 bits represent coordinates within a range of -1024 to +1023.

To use the Calibrate Raw command, the controller and host system must be in an 8-bit data communication mode. The Calibrate Raw command returns a negative response if the controller is not using an 8-bit communication mode. To end Calibrate Raw mode, issue a Reset command.

3M Touch Systems uses the Calibrate Raw command during manufacturing and testing, and recommends you only use this command for diagnostics when you want raw data.

Response: <SOH>**0**<CR> Positive response.

After the controller is in Calibrate Raw mode, the controller returns a response in the following format:

SXxYy where:

S = Status byte, first byte of data. Refer to Table 6.

Xx = X (horizontal) coordinate data; second and third bytes of data

Yy = Y (vertical) coordinate data; fourth and fifth bytes of data.

Table 6 Data Sequence

Data Sequence	MSB*		Bits					LSB*
	7	6	5	4	3	2	1	0
S- Byte 1	1	S6	Reserved					
X- Byte 2	0	X3	X2	X1	X0	Reserved		
x- Byte 3	0	Xs**	X9	X8	X7	X6	X5	X4
Y- Byte 4	0	Y3	Y2	Y1	Y0	Reserved		
y- Byte 5	0	Ys**	Y9	Y8	Y7	Y6	Y5	Y4

*MSB = Most Significant Bit, LSB = Least Significant Bit

** s = sign bit

Table 7 describes the meaning of the bits in the status byte (Byte 1).

Table 7 Calibrate Raw Status Bits

Bit	Description	Values
S0 – S5	Reserved	—
S6	Proximity (touch state)	1 = Sensor is being touched (a touchdown or a continued touch). 0 = Sensor is not being touched (a touch liftoff or inactive). When the proximity bit changes from 1 to 0 (touch liftoff), the controller outputs one final set of X/Y coordinate data with the bit equal to 0 and the X/Y coordinate data equal to the last touch point.

Bit	Description	Values
S7	Packet synchronization	Always 1.

Diagnostic Command

Syntax: <SOH>**DX**<CR>

Description: This command requests that the controller check for sensor failures such as broken corners, broken wires, etc.

Response: <SOH>**0**<CR> Positive response.
 <SOH>**1**<CR> Command not supported.
 <SOH>**2**<CR> Failure detected.

Format Raw

Syntax: <SOH>**FR**<CR>

Description: Returns the signal level (amount of touch) of each of the four sensor corners in digital format. The returned values are not corrected for stray values.

The Format Raw data is a 41-byte packet that includes 1 status byte and 40 bytes of binary corner data. The first byte of each packet always has its high bit (Bit 7) set to provide synchronization with the host system. Refer to Table 8 for General Packet Formats. Each corner data is composed of a pair of 32-bit I and Q values, which are delivered in 10 bytes.

I and Q are complex touch currents as measured in phase and 90 degrees out of phase with the corner drive signal. Refer to Table 9 for I/Q Corner Components.

To use the Format Raw command, the controller and host system must be in an 8-bit data communication mode. The Format Raw command returns a negative response if the controller is not using an 8-bit communication mode.

To terminate Format Raw, issue a Reset command. The controller may return several bytes of data between the time you issue a Reset command and the controller receives it. You can either scan the data stream for the Reset acknowledgment, or you can ignore the response to the first Reset command and then issue a second Reset after approximately 10 seconds has passed.

Use the Format Raw command for diagnostics. Use Format Tablet for standard sensor operation.

Response: <SOH>**0**<CR> Positive response.

After the controller is in Format Raw mode, the controller returns a continuous response in the following format:

<41-byte-packet><41-byte-packet>...<41-byte-packet>...

Table 8 General Packet Formats

Byte	Bits 0 – 7
1	b0 – b6: Reserved b7: Synchronization bit (Always 1)
2-6	I component of upper left (UL) corner
7-11	Q component of upper left (UL) corner
12-16	I component of upper right (UR) corner
17-21	Q component of upper right (UR) corner
22-26	I component of lower left (LL) corner
27-31	Q component of lower left (LL) corner
32-36	I component of lower right (LR) corner
37-41	Q component of lower right (LR) corner

Table 9 I/Q Corner Components

Byte	Bits 0 – 7
N	b0 – b6: bits 25-31 of respective I/Q corner data b7: Always 0
N+1	b0 – b6: bits 18-24 of respective I/Q corner data b7: Always 0
N+2	b0 – b6: bits 11-17 of respective I/Q corner data b7: Always 0
N+3	b0 – b6: bits 4-10 of respective I/Q corner data b7: Always 0
N+4	b0 – b3: bits 0-3 of respective I/Q corner data b4 – b7: Always 0

Format Tablet

Syntax: <SOH>**FT**<CR>

Description: Outputs the X/Y touch coordinate data in a 5-byte packet. The packet includes 1 status byte and 4 bytes of binary X/Y coordinate data. The protocol also establishes the X and Y coordinate output as 14 binary bits providing a range of 0 to 16,383.

The low order bits (X3 – X0 and Y3 – Y0) are not significant in a 1024 by 1024 sensor because data can fluctuate with each touch, and therefore may not be completely accurate.

To use Format Tablet, the controller and host system must be in an 8-bit data communication mode. The Format Tablet command returns a negative response if the controller is in 7-bit format.

Response: <SOH>**0**<CR> Positive response.

With the controller in Format Tablet mode, touching the sensor causes the controller to return a response in the following format:

SXxYy

S = Status byte, first byte of data. Refer to Table 10.

Xx = X (horizontal) coordinate data; second and third bytes of data.

Yy = Y (vertical) coordinate data; fourth and fifth bytes of data.

Table 10 Data Sequence

Data Sequence	MSB*		Bits					LSB*	
	7	6	5	4	3	2	1	0	
S	Byte 1	1	S6	S5	S4	S3	S2	S1	S0
X	Byte 2	0	X6	X5	X4	X3	X2	X1	X0
x	Byte 3	0	X13	X12	X11	X10	X9	X8	X7
Y	Byte 4	0	Y6	Y5	Y4	Y3	Y2	Y1	Y0
y	Byte 5	0	Y13	Y12	Y11	Y10	Y9	Y8	Y7

*MSB = Most Significant Bit, LSB = Least Significant Bit

Table 11 defines the status bits (Byte 1) for the Format Tablet data.

Table 11 Format Tablet Status Bits

Bit	Description	Values
S0 – S5	Reserved	—
S6	Proximity (touch state)	1 = Sensor is being touched (a touchdown or a continued touch). 0 = Sensor is not being touched (a touch liftoff or inactive). When the proximity bit changes from 1 to 0 (touch liftoff), the controller outputs one final set of X/Y coordinate data with the bit equal to 0 and the X/Y coordinate data equal to the last touch point.
S7	Packet synchronization	Always 1.

Mode Stream

Syntax: <SOH>**MS**<CR>

Description: Sends a continuous stream of X/Y coordinate data when you touch the sensor. The controller continues to send data as long as you touch the sensor. The controller sends the data even if the touch is stationary and unchanging.

The format of the coordinate data depends on the last format command received by the controller.

Response: <SOH>**0**<CR> Positive response.

Name Command

Syntax: <SOH>**NM**<CR>

Description: This command returns a string of characters to help identify the controller. The string contains the controller model number and current firmware revision number. The content and format of this command can change and therefore is not intended for normal customer use.

Null Command

Syntax: <SOH>**Z**<CR>

Description: Queries the controller and waits for a response.

Use Z to determine that you are communicating with the controller or to make sure that a utility is communicating with the controller. Using this command does not affect the controller's current operating parameters.

Response: <SOH>**0**<CR> Positive response.

Output Identity

Syntax: <SOH>**O**I<CR>

Description: Returns a 6-character random identifier, which describes the controller type and the firmware version number.

Response: <SOH>*CcXxx*<CR>

where:

Cc = Two ASCII characters that describe the type of 3M™ MicroTouch™ controller.

Xxxx = Four ASCII characters that indicate a build identifier.

Parameter Set

Syntax: <SOH>**P***pds*[*b*]<CR>

where:

p = Parity type

N = No parity

O = Odd parity

E = Even parity

d = Number of data bits (**7** or **8**).

s = Number of stop bits (**1** or **2**)

b = Communication rate

1 = 19200 baud **4** = 2400 baud

2 = 9600 baud **5** = 1200 baud

3 = 4800 baud

Description: Lets you adjust the communication parameters (parity, data bits, and stop bits) of the controller. Optionally, you can change the communication rate by appending an additional character to the command string. Upon execution of the Parameter Set command, the controller automatically stores the new settings, the current operating mode, and the current data format in NOVRAM.

The communication parameters of the host system must match the present settings of the controller when the command is given for it to be accepted and the changes implemented.

The process of changing the parameters takes three steps:

- The host system must first communicate with the controller using a matched set of parameters.
- The Parameter Set command is issued with the new parameters to the controller. The new settings take effect immediately.
- The host system must be changed to the new parameters in order to communicate with the controller again.

Examples: <SOH>PN813<CR> Sets the serial line to no parity, eight data bits, one stop bit, and 4800 baud.

<SOH>PN81<CR> Sets the parity, data bits, and stop bits; leaves the baud at its previous value.

Caution: The settings are immediately written to NOVRAM, and all future communication must occur at the new values. It is possible to set the parameters to values that prevent future communication with the controller.

Response: <SOH>0<CR> Positive response.

Reset

Syntax: <SOH>R<CR>

Description: Initializes the hardware and the firmware, causes the controller to stop sending data, and recalculates the environmental conditions (for example, stray and offset values). The Reset command also cancels the Format Raw, Calibrate Raw, and Calibrate Extended commands and returns the controller to normal operation.

3M Touch Systems recommends that the host system issue a Reset command whenever the host system is powered on and is attempting to establish communication with the controller.

The amount of time needed to execute a Reset command ranges from 225 milliseconds to 800 milliseconds. Therefore, the application program should wait and be sure it receives the command response before issuing another command to the controller following the reset.

Response: <SOH>0<CR> Positive response.

Restore Defaults

Syntax: <SOH>RD<CR>

Description: Returns to the factory default operating parameters. The Restore Defaults command copies the 3M Touch Systems factory default parameters from ROM to the non-volatile memory (NOVRAM) and then executes a Reset command.

Table 12 lists the factory defaults for the EX serial controller. The Restore Defaults command is useful in situations where inadvertent commands to the controller have rendered the sensor inoperative.

Table 12 EX Serial Controller Factory Default Settings

Operating Parameter	Default
Baud Rate	9600
Serial Communication Settings	N, 8, 1 ¹
Data Format	Format Tablet
Operating Mode	Mode Stream
Return to Factory Calibration	Yes

The Restore Defaults command requires approximately 1.8 seconds. Therefore, the application program should wait the maximum amount of time and be sure it receives the command response before issuing another command to the controller.

Note: After you issue a Restore Defaults command, you must recalibrate your sensor using a 2-point calibration.

Response: <SOH>**0**<CR> Positive response.

Unit Type Verify

Syntax: <SOH>**UV**<CR>

Description: Responds with an 8-character identity string. This string identifies the type of controller currently attached to the system, lists the features supported by the controller, and outputs the status of the controller hardware (a self-test code).

Response: Returns an identification code up to 8 ASCII characters in the following format:

<SOH>*TtFfffSs*<CR>

where:

Tt = Two ASCII characters that identify the controller type.

QM = Serial controller

Ffff = Four ASCII characters that indicate the features supported by the controller.

R= Indicates a resistive controller

V= Indicates the serial controller

********= Indicates no additional features configured

¹ Some EX122 can operate at N, 7, 2.

- Ss* = Two ASCII characters that provide status information about the controller hardware. The two characters represent one byte. Each character is in the range 0 to 9 and A to F.
Table 2 defines the meaning of each bit (LED minus 1) in the status byte. Each bit can be set to 1 or 0, where:
- 1** = Error
 - 0** = No error
 - 00** = No diagnostic errors (normal response)

APPENDIX A

EX122 Controller Specifications

This section provides EX122 controller specifications such as power requirements, environmental requirements, and cable connectors.

The EX122 controller is a compact (3.5 x 2.25 x 0.3 inches), RS-232 serial controller. This controller can be internally mounted in your display, or enclosed in a molded plastic case (3.75 x 2.5 x 0.9 inches) and mounted to the back or side of your display.

The following figures show the overall dimensions of the EX122 controller and the locations of the mounting holes and connectors.

Figure 1 Uncased EX122 Touch Controller

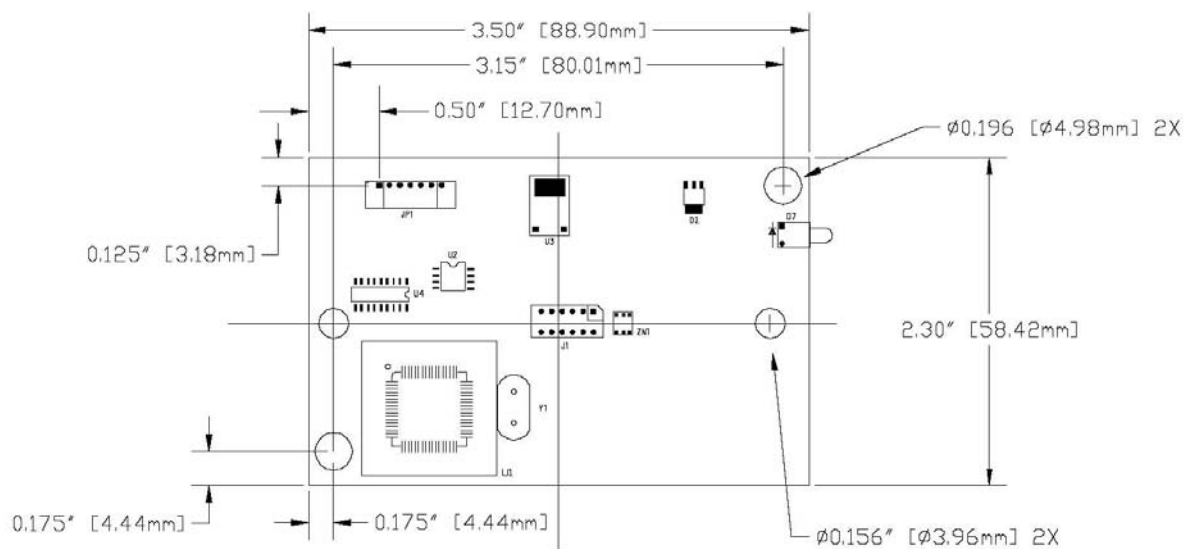
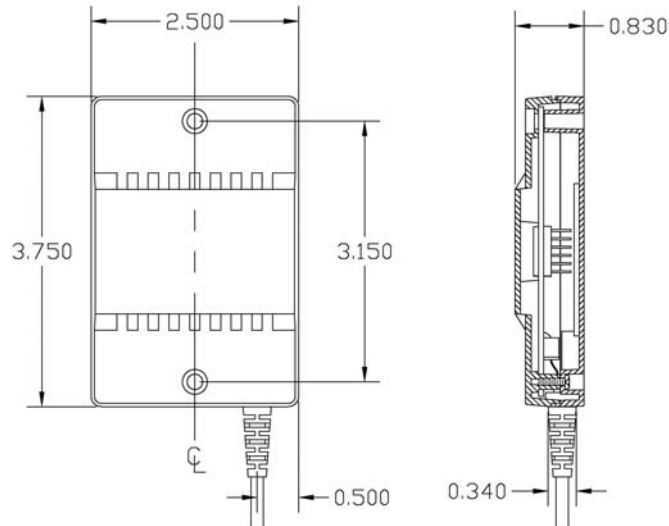

Figure 2 Cased EX122 Touch Controller

Technical Specifications

The controller specifications listed below were validated in test systems containing 3M Touch Systems components. These specifications may not be valid if configured with components from suppliers other than 3M Touch Systems. All components in the manufacture of electronic controllers are RoHS Directive compliant (2002/95/EC).

Physical Dimensions

Uncased	3.50 in. x 2.30 in. x 0.45 in.	(88.9 mm x 58.4 mm x 11.4 mm)
Cased	3.75 in. x 2.50 in. x 0.90 in.	(95.3 mm x 63.5 mm x 22.9 mm)

Board Level Functions

Power

- 5 VDC (80 mA typical, 100 mA maximum); $\pm 5\%$ regulation 50 mV_{pp} maximum ripple and noise
- 12 VDC (85 mA typical, 100 mA maximum); $\pm 10\%$ regulation 50 mV_{pp} maximum ripple and noise

Regulatory Requirements

CE		Compliant
Radiated Emissions – EN 55022:1998	Class B	Compliant
AC Mains Conducted Emissions – EN 55022:1998	Class B	Compliant
Telco Lines Conducted Emissions	N/A	N/A
FCC Class B / CISPR22 Class B	Class B	Compliant
VCCI Class B ITE Emissions (Japan)	Class B	Compliant
AS/NZS 3548:1995/CISPR 22 Class B ITE Emissions (Aus.)	Class B	Compliant
RFI – EN 61000-4-3 / ENV 50140	Class A	Compliant
CRFI – EN 61000-4-6	N/A	Cable < 3 meters long

	Class A	< 80% Screen Area	
	Class B	≥ 80% Screen Area	N/A
EFT (Burst Immunity) – EN 61000-4-4	Class B		Compliant
ESD Susceptibility – IEC 61000-4-2	Class 1		Compliant
Surge – EN 61000-4-5	Class B		Compliant
Harmonics – EN 61000-3-2	Class A		Compliant
Flicker – EN 61000-3-3			Compliant
Power Frequency Magnetic Field – EN 61000-4-8	Class A		Compliant
Voltage Dips – EN 61000-4-11	Class B	< 5% V	
	Class C	< 70% V	Compliant
Voltage Interruptions – EN 61000-4-11	Class C		Compliant
UL/cUL			Compliant

Ambient Operating and Storage Environmental Conditions

All Humidity is Non-Condensing

Operating Temperature Range - 40 °C to +70 °C

Operating Humidity Range < 36° C 0-95% RH ≥ 36 °C

Storage Temperature Range - 50 °C to +85 °C

Storage Humidity Range < 36°C 0-80% RH ≥ 36 °C

Performance and Reliability

Minimum Touch Duration As low as 3 msec.

Touch Resolution – (Maximum addressable coordinates generated by the controller) 16K x 16K

ESD Susceptibility -

±8 kV Contact Discharge* – Class 2 per section 9 of IEC 61000-4-2 Compliant

1 false touch allowed

±27 kV Air Discharge* – Class 1 per section 9 of IEC 61000-4-2 Compliant

Normal Operation – No false touches

* ESD discharges to a 3M™ MicroTouch™ sensor connected to the controller

MTBF (by MIL Std. 217F Calculation) > 740,000 Hours

Touch System Parameters

Accuracy vs. Dynamic Temperature Change Maintains 1% Accuracy
(tested at 0 deg. C to 60 deg. C with a 0.5 deg. C/minute temperature ramp)

Sensor Compatibility 3M™ MicroTouch™ Capacitive Sensors

Communications Protocol Serial RS 232

APPENDIX B

EX112 Controller Specifications

This section provides EX112 controller specifications such as power requirements, environmental requirements, and cable connectors.

The EX112 controller is a compact RS-232 serial controller. This controller can be internally mounted in your display.

The following figures show the overall dimensions of the EX112 controller and the locations of the mounting holes and connectors.

Figure 3 EX112 Touch Controller

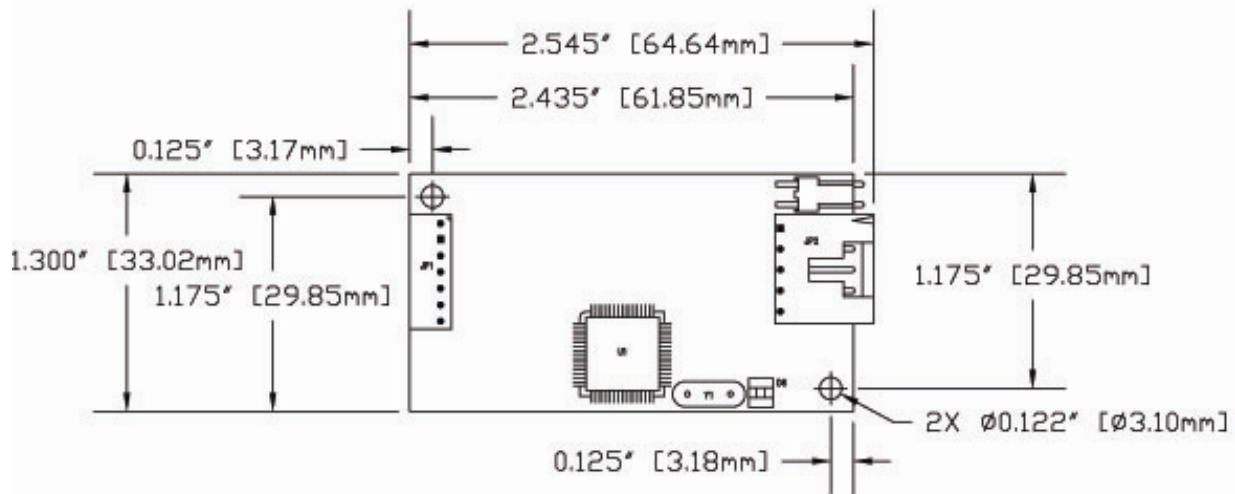

Technical Specifications

The controller specifications listed below were validated in test systems containing 3M Touch Systems components. These specifications may not be valid if configured with components from suppliers other than 3M Touch Systems. All components in the manufacture of electronic controllers are RoHS Directive compliant (2002/95/EC).

Physical Dimensions

Uncased 2.55 in. x 1.30 in. x 0.45 in. (65.0 mm x 33.0 mm x 11.4 mm)

Board Level Functions

Power 5 to 12 VDC (85 mA typical, 110 mA maximum); ± 5% regulation
50 mV_{pp} maximum ripple and noise

Regulatory Requirements

CE			Compliant
Radiated Emissions – EN 55022:1998	Class B		Compliant
AC Mains Conducted Emissions – EN 55022:1998	Class B		Compliant
Telco Lines Conducted Emissions	N/A		N/A
FCC Class B / CISPR22 Class B	Class B		Compliant
VCCI Class B ITE Emissions (Japan)	Class B		Compliant
AS/NZS 3548:1995/CISPR 22 Class B ITE Emissions (Aus.)	Class B		Compliant
RFI – EN 61000-4-3 / ENV 50140	Class A		Compliant
CRFI – EN 61000-4-6	N/A	Cable < 3 meters long	
	Class A	< 80% Sensor Area	
	Class B	≥ 80% Sensor Area	
	N/A		
EFT (Burst Immunity) – EN 61000-4-4	Class B		Compliant
ESD Susceptibility – IEC 61000-4-2	Class 1		Compliant
Surge – EN 61000-4-5	Class B		Compliant
Harmonics – EN 61000-3-2	Class A		Compliant
Flicker – EN 61000-3-3			Compliant
Power Frequency Magnetic Field – EN 61000-4-8	Class A		Compliant
Voltage Dips – EN 61000-4-11	Class B	< 5% V	
	Class C	< 70% V	Compliant
Voltage Interruptions – EN 61000-4-11	Class C		Compliant
UL/cUL			Compliant

Ambient Operating and Storage Environmental Conditions

All Humidity is Non-Condensing	
Operating Temperature Range	- 40 °C to +70 °C
Operating Humidity Range	<36° C 0-95% RH ≥ 36 °C
Storage Temperature Range	- 50 °C to +85 °C
Storage Humidity Range	< 36°C 0-80% RH ≥ 36 °C

Performance and Reliability

Minimum Touch Duration	As low as 3 msec.
Touch Resolution – (Maximum addressable coordinates generated by the controller) 16K x 16K	
ESD Susceptibility -	
±8 kV Contact Discharge* – Class 2 per section 9 of IEC 61000-4-2	Compliant
1 false touch allowed	
±27 kV Air Discharge* – Class 1 per section 9 of IEC 61000-4-2	Compliant
Normal Operation – No false touches	
* ESD discharges to a 3M™ MicroTouch™ sensor connected to the controller	
MTBF (by MIL Std. 217F Calculation)> 700,000 Hours	

Touch System Parameters

Accuracy vs. Dynamic Temperature Change	Maintains 1% Accuracy
(tested at 0 deg. C to 60 deg. C with a 0.5 deg. C/minute temperature ramp)	
Sensor Compatibility	3M™ MicroTouch™ Capacitive Sensors
Communications Protocol	Serial RS 232